

# UTILITY HOT HEAD PRESS

AHP-554U

## PRODUCT FEATURES



- **Sturdy Design**
- **Flat Table for Easy Garment Flow**
- **Satin Smooth Press Head Finish**
- **Built in Safety Features**



# PRODUCT SPECIFICATIONS

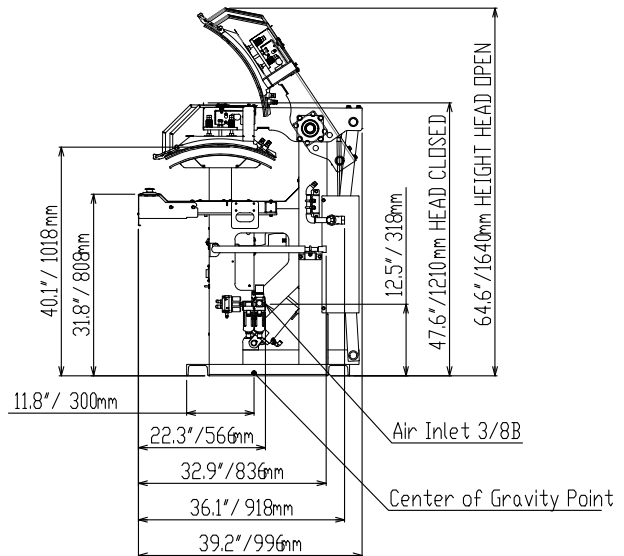
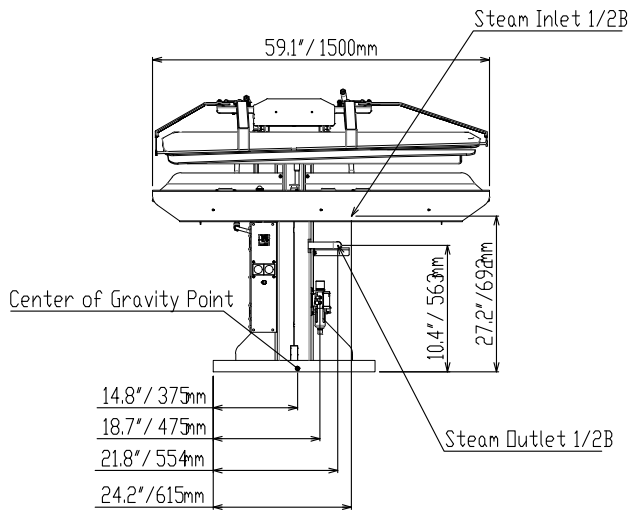
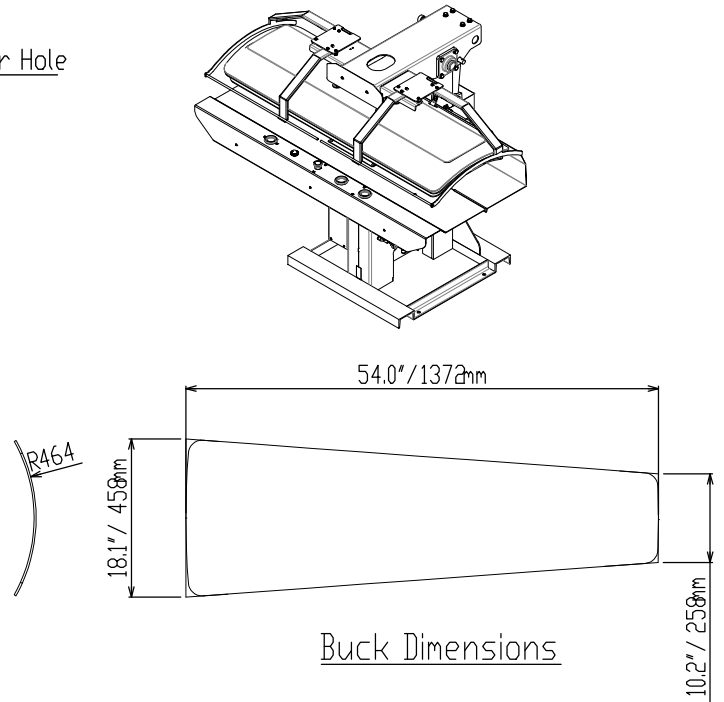
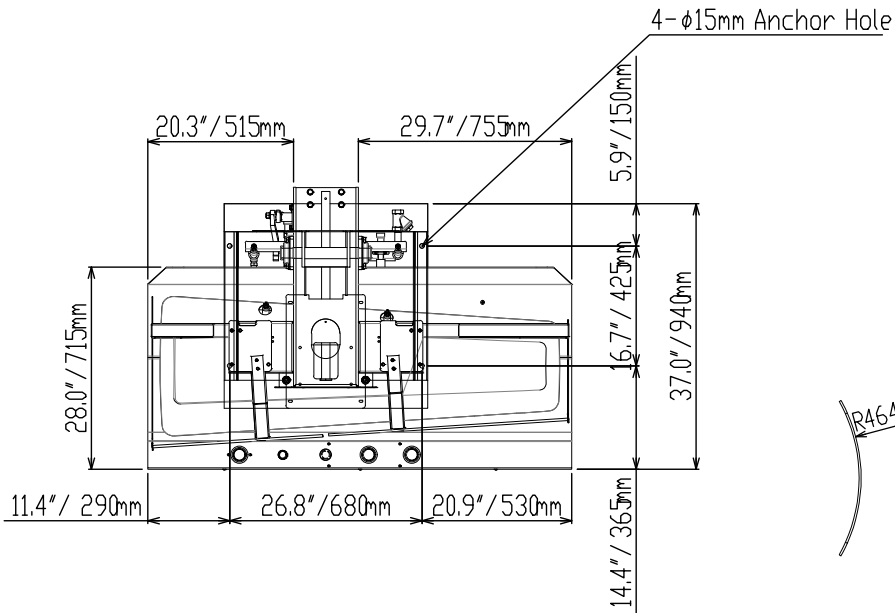

UTILITY HOT HEAD PRESS • MODEL AHP-554U			
Power	110-220V Single ph 0.14A	Air Connection	3/8B
Weight	726lb / 330kg	Steam Connection	Inlet: 1/2B, Outlet 1/2B
Air Consumption	0.5 cfm	Dimension (mm)	1500 x 996 x 1670
Steam Consumption	1.5 BHP	(W x D x H) (inch)	59.1" x 39.2" x 65"
Air Pressure	73 psi / 0.5 Mpa	Buck Size	54" x 18.1" x 10.2"
Steam Pressure	73 psi / 0.5 Mpa		